

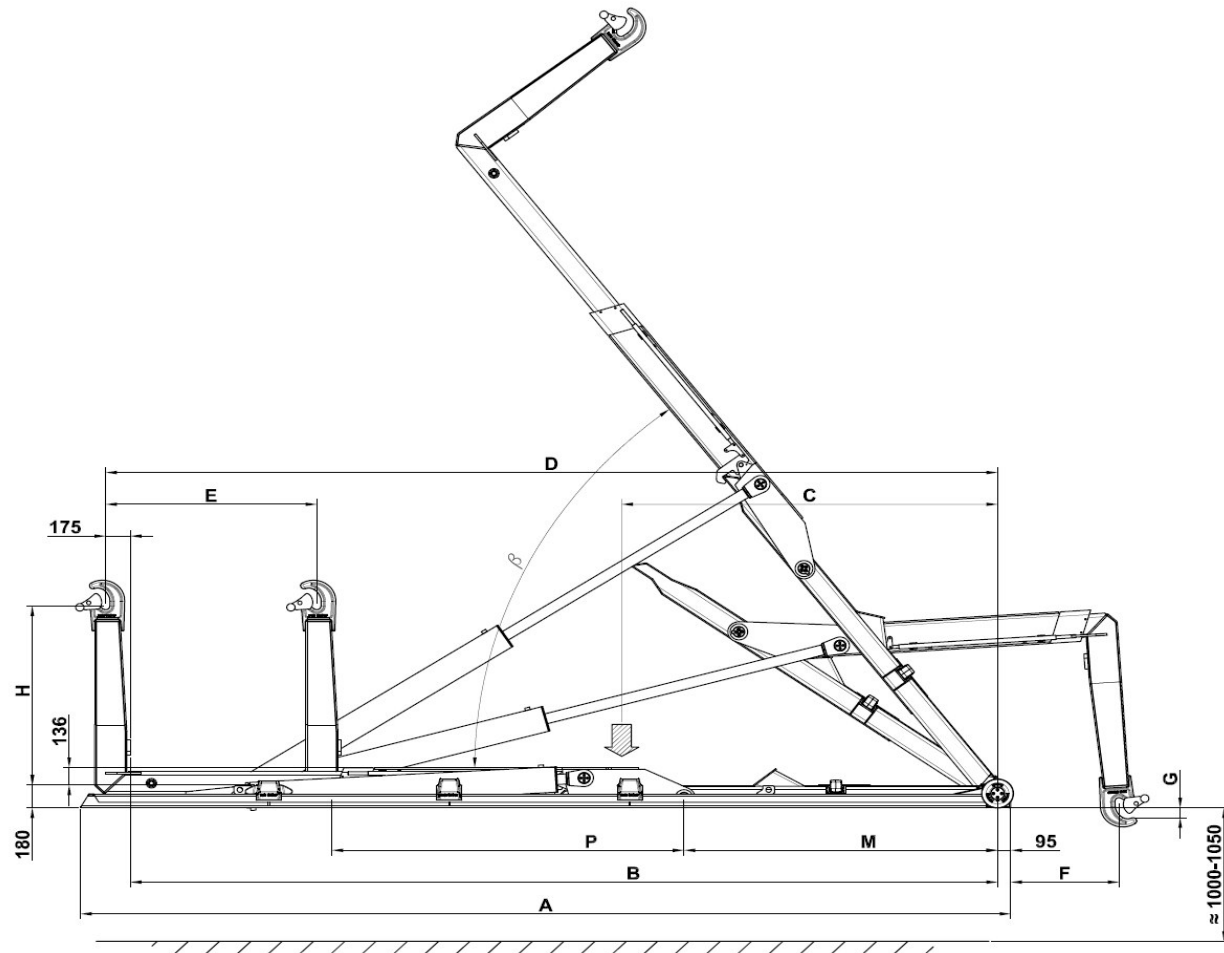

**BUSI
GROUP**

SC 016

SCARRABILE CON SFILLO E RIBALTAMENTO

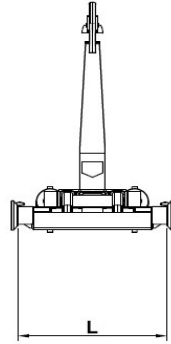

Modele Equip	Charge Max	Poids Equip	Angle	Pompe 1000 Tours	Press. Max Tours	Dimensions											Container	
Equipment Model	Max Load	Equip Weight	Angle	1000 RPM Pump	Rev. Max Pressu	Dimensions											Cage	
Modello Scarrabile	Portata	Peso Scarr.	Angolo	Pompa 1000 Giri	Press. Max Giri	Dimensioni											Cassa	
	TON.	Kg.	β	Litri	Bar	A	B	C	D	E	H	F	G	L	M	P	K MIN.	K MAX
SC 016 / 42	16	1860	54	60	320	4725	4025	2423	4200	715	1430 / 1570	1095 / 1155	-80 / -205	1065	1450	1930	3600	4800
SC 016 / 44	16	1860	54	60	320	4725	4225	2451	4400	915	1430 / 1570	1095 / 1155	-80 / -205	1065	1450	1930	3600	5000
SC 016 / 46	16	1895	54	60	320	4875	4425	2502	4600	915	1430 / 1570	1270 / 1335	10 / -115	1065	1450	2130	3800	5200
SC 016 / 48	16	1900	54	60	320	5075	4625	2542	4800	1115	1430 / 1570	1270 / 1335	10 / -115	1065	1450	2130	3800	5400
SC 016 / 50	16	1975	52	60	320	5475	4825	2833	5000	915	1430 / 1570	880 / 915	-95 / -230	1065	1850	2130	4200	5600
SC 016 / 52	16	1975	52	60	320	5475	5025	2861	5200	1115	1430 / 1570	880 / 915	-95 / -230	1065	1850	2130	4200	5800
SC 016 / 54	16	2010	52	60	320	5675	5225	2915	5400	1115	1430 / 1570	1070 / 1110	-45 / -175	1065	1850	2330	4400	6000
SC 016 / 56	16	2015	52	60	320	5875	5425	2955	5600	1315	1430 / 1570	1070 / 1110	-45 / -175	1065	1850	2330	4400	6200

2008