

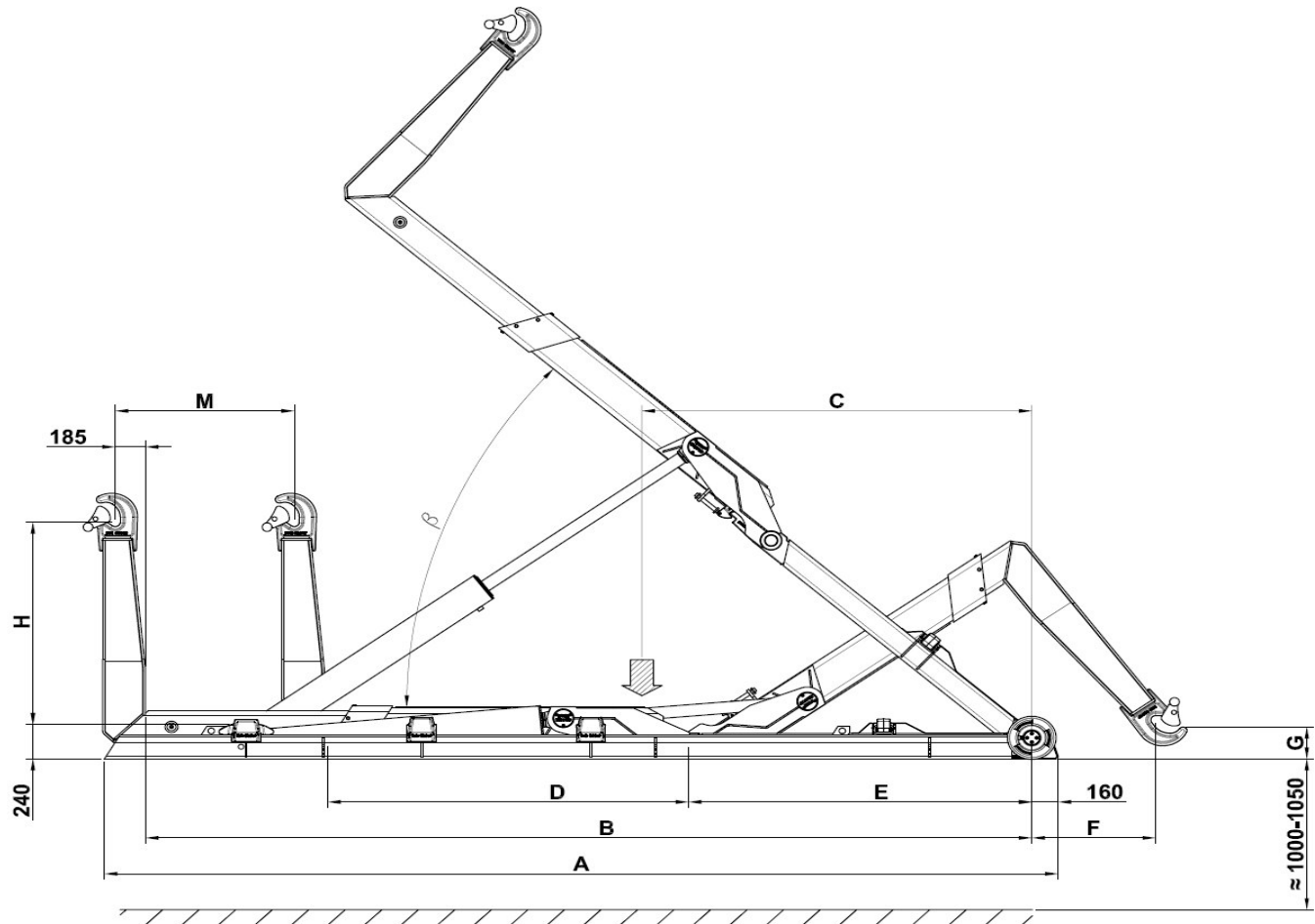

**BUSI
GROUP**

SC 266

SCARRABILE CON SFILLO E RIBALTAMENTO

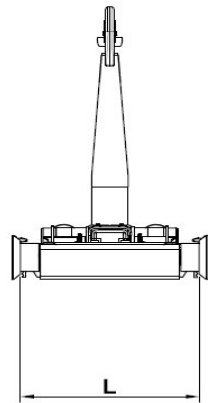

Modele Equip	Charge Max	Poids Equip	Angle	Pompe 1000 Tours	Press. Max Tours	Dimensions										Container	
Equipment Model	Max Load	Equip Weight	Angle	1000 RPM Pump	Rev. Max Pressu	Dimensions										Cage	
Modello Scarrabile	Portata	Peso Scarr.	Angolo	Pompa 1000 Giri	Press. Max Giri	Dimensioni										Cassa	
	TON.	Kg.	β	Litri	Bar	A	B	C	D	E	F	G	H	L	M	K MIN.	K MAX
SC266 XL	26	2675	42°	95	340	5860	5450	3200	2235	2110	760 / 855	220 / 90	1430 / 1570	1070	1100	4700	6400
SC 266 L	26	2630	42°	95	340	5760	5350	3150	2235	2110	760 / 855	220 / 90	1430 / 1570	1070	1000	4700	6300
SC266 NL	26	2590	45°	95	340	5560	5150	3100	2235	1910	960 / 1055	220 / 90	1430 / 1570	1070	1000	4500	6100
SC266 N	26	2555	45°	95	340	5360	4950	3050	2235	1710	1160 / 1255	220 / 90	1430 / 1570	1070	1000	4300	5900
SC 266 NC	26	2525	48°	95	340	5160	4750	3000	2035	1710	1000 / 1095	100 / -30	1430 / 1570	1070	1000	4100	5700
SC 266 C	26	2500	51°	95	340	4960	4550	2950	2035	1510	1200 / 1295	100 / -30	1430 / 1570	1070	1000	3900	5500
SC 266 XC	26	2480	54°	95	340	4760	4350	2900	2035	1310	1400 / 1495	100 / -30	1430 / 1570	1070	1000	3700	5300

2008