

# VT-145-F

MB SPRINTER / VW CRAFTER WB 3665 (5T)



**TIME**

# VT-145-F

## SPECIFICATION

	VT-145-F (5°/10°)	VT-145-F (5°/10°)
Working height	14.60 m	14.60 m
Platform height	12.60 m	12.60 m
Max. working outreach	8.5 / 7.8 m*	9.5 / 8.5 / 7.8 m*
Max. bucket capacity	120 / 200 kg	120 / 200 / 265 kg
Flyboom	200°	200°
Minimum GVW of the vehicle	5000 kg	5000 kg

\* Depending on vehicle

## STANDARD

USS: Up-under subframe system

RO: Up-under radial outriggers

No tail swing outside the mirrors of the vehicle

ALS: Axle Lock System

ES: Emergency pump system

2 Man Euro bucket

VP: 230 V connection to bucket (HPFI)

PSA: Rearplatform, bucket stowed Asymmetric

FPC: Full proportional CANbus control

Display in bucket

OOS: Optimized outreach /Canbus

1 KV insulation

## OPTIONS

12 V DC Air Compressor

12 V/230 V Inverter

AEP: Access Enviromental Powerpack (HYBRID)

TH: Trailerhook removable, only rear platform

WTS: Walk Through System

LSO : Load Sensing Outreach / CanBus

LRA: Limited work area without outriggers

Self pack

ADS: Access drive system

Bucket rotator 2 x 85°

## NOTE

<sup>1)</sup> Display of the reach (position) with working height and outreach, error diagnosis

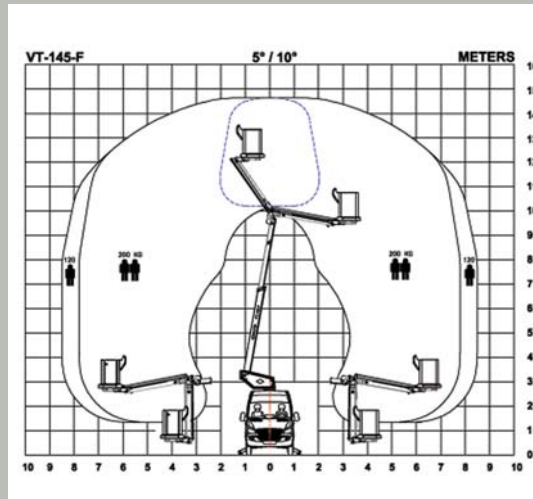
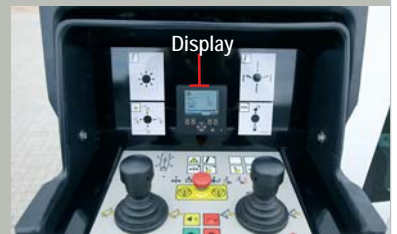

With short outriggers (2450 mm)

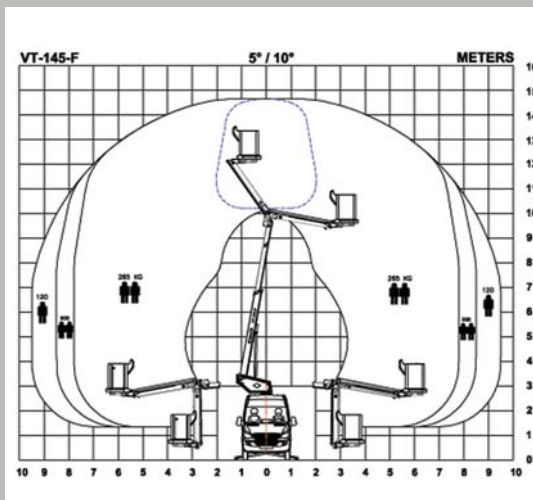

With long outriggers (2650 mm)

VT-145-LF/V590/SprinterCrafter5T/2012-02/UK



INTERNATIONAL A/S

Søndervang 3 - DK-9640 Farsø

Phone +45 9863 2433 - Fax +45 9863 2483

sales@TIMEintl.dk - www.TIMEintl.dk